

# HIGHLANDER II VERTICAL PLATFORM LIFT

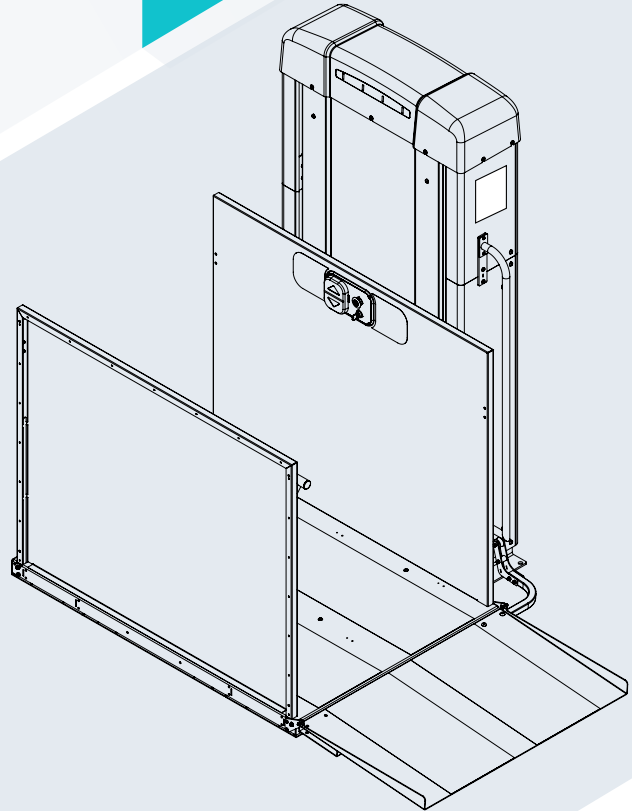

OWNER'S  
MANUAL



## **THANK YOU**

From all of us at Harmar, thank you for placing your trust in our products and allowing us to be a part of your journey.

For more than 20 years we have been committed to creating products that help you maintain independence. With a drive to empower people to live as they choose, Harmar Lifts Lives.

Beyond vertical platform lifts, like the one you've purchased, Harmar designs and manufactures Vehicle Lifts, award-winning Stair Lifts, and more.

We strive to be the leading provider of lift assisting technology in your home and on the road.

Visit [harmar.com](http://harmar.com) or speak to your dealer about the other solutions available from Harmar.

**TABLE OF CONTENTS**

**SAFETY..... 4**  
 Safety Definitions..... 4  
 Special Cautions..... 4

**INTRODUCTION ..... 5**  
 Device Name: Harmar Highlander II VPL..... 5  
 Read and Understand..... 5  
 Purchasing Information ..... 5  
 Technical Specifications ..... 5  
 Code Statement ..... 5  
 Key Vertical Platform Lift Elements..... 6  
 Key Internal Vertical Platform Lift Elements..... 7

**OPERATION..... 8**  
 How the Harmar Highlander II Works..... 8  
 Lift Operation ..... 8  
 Call/Send ..... 8  
 Entering the Platform..... 8  
 Operating the Platform Controls..... 9  
 Exiting the Platform ..... 9  
 Recommendations ..... 10  
 Emergency Lowering Procedure ..... 10

**TROUBLESHOOTING..... 12**  
 Status Codes ..... 12

**CARE ..... 14**

**MAINTENANCE & INSPECTION ..... 15**  
 Required Inspections & Maintenance..... 15  
 Residential Application: Owner/Maintenance ... 15  
 Commercial Application:  
 End-User/Maintenance ..... 15  
 Dealer Maintenance Schedule..... 16  
 Service Mode ..... 16  
 Out of Service Mode ..... 16  
 Maintenance/Service Record ..... 17

**WARRANTY..... 20**



SECTION 1

**SAFETY**

**SAFETY DEFINITIONS**



This safety alert symbol appears with safety statements. It means attention, become alert, your safety and the safety of others are involved! Please read and abide by the message that follows the safety alert symbol.

 **WARNING**

Indicates a hazardous situation that, if not avoided, could result in death or serious injury.

 **CAUTION**

Indicates a hazardous situation that, if not avoided, could result in minor or moderate injury.

**NOTICE**

*Indicates a situation which can cause damage to the lift and/or the environment, or cause the lift to operate improperly.*

*NOTE: Indicates a condition that should be followed in order for the lift to function in the manner intended.*

**SPECIAL CAUTIONS**



Pay attention to the following Special Cautions while operating your vertical platform lift.

- Do not exceed the maximum payload capacity of 750 lb.
- Do not ride on a lift that is not anchored in place.
- Make sure any obstructions are cleared from underneath the platform area before use.
- Make sure both the passenger and wheelchair are completely on the platform before using.
- Do not disable any safety equipment or switches supplied with this lift.
- Do not attempt to service the lift yourself. Contact your Harmar dealer for assistance.
- Do not allow children to operate or play around the lift.
- Do not enter or exit a platform by climbing over a gate or side panel.
- Keep feet, hands, arms, legs and body well within the confines of the platform during transport.
- Do not hold onto the top of the side panel or gate during transport as this creates a potential pinch hazard.
- This product is designed only for lifting people and wheelchairs within the specified load capacity. Do not use it for freight or any other purpose.
- Read all instructions in this manual before installing or operating the lift.

## SECTION 2

**INTRODUCTION****DEVICE NAME:  
HARMAR HIGHLANDER II -  
VERTICAL PLATFORM LIFT**

Indications of Use: The Harmar Highlander II Vertical Platform Lift is to assist the transfer of patients or mobility impaired persons and their mobility device, up and down levels of a commercial facility or residence.

**READ AND UNDERSTAND**

This manual provides instructions for proper use and maintenance of your Vertical Platform Lift. Please refer to this Owner's Manual for operating instructions. Any alterations to the equipment without written authorization by the manufacturer is prohibited and will void the warranty.

**PURCHASING  
INFORMATION**

If you have questions concerning the operation and maintenance of your Vertical Platform, please contact your dealer.

Please ensure that you fill out the separate warranty form and return it within ten (10) days of purchase to register your lift.

**TECHNICAL  
SPECIFICATIONS**

Visit [harmar.com](http://harmar.com) for specifications on your lift model.

**CODE STATEMENT**

Your lift has been designed to meet "Safety Standard for Platform Lifts and Stairway Chairlifts" under section 2 or section 5 and has been certified to CSA B44.1/ASME A17.5-2019, Safety standard ASME A18.1-2020 "Elevator and Escalator Electrical Equipment".

Code requirements for Vertical Platform lifts may vary depending on location. It is the installer's responsibility to contact their state, city or local code enforcement office and determine all the regulations the lift and installation are subject to. This must be done before installing the Vertical Platform Lift.

Harmar Vertical Platform Lifts are to be installed in accordance with all applicable codes and in accordance with CSA B44.1/ASME A17.5-2019 and Safety standard ASME A18.1-2020.

The Vertical Platform Lift units are intended for a maximum operation of 24-cycles per hour for units up to 101" and 12-cycles per hour for units greater than 101".

# INTRODUCTION

## KEY VERTICAL PLATFORM LIFT ELEMENTS

1. Top Cap
2. Lift Status Indicator Lights
3. Data Serial Tag
4. Platform
5. Platform Side Panel
6. Grab Rail (if supplied)
7. Platform Controls
8. Platform Safety Pan
9. Platform Folding Ramp/  
Platform Fixed Ramp
10. Tower

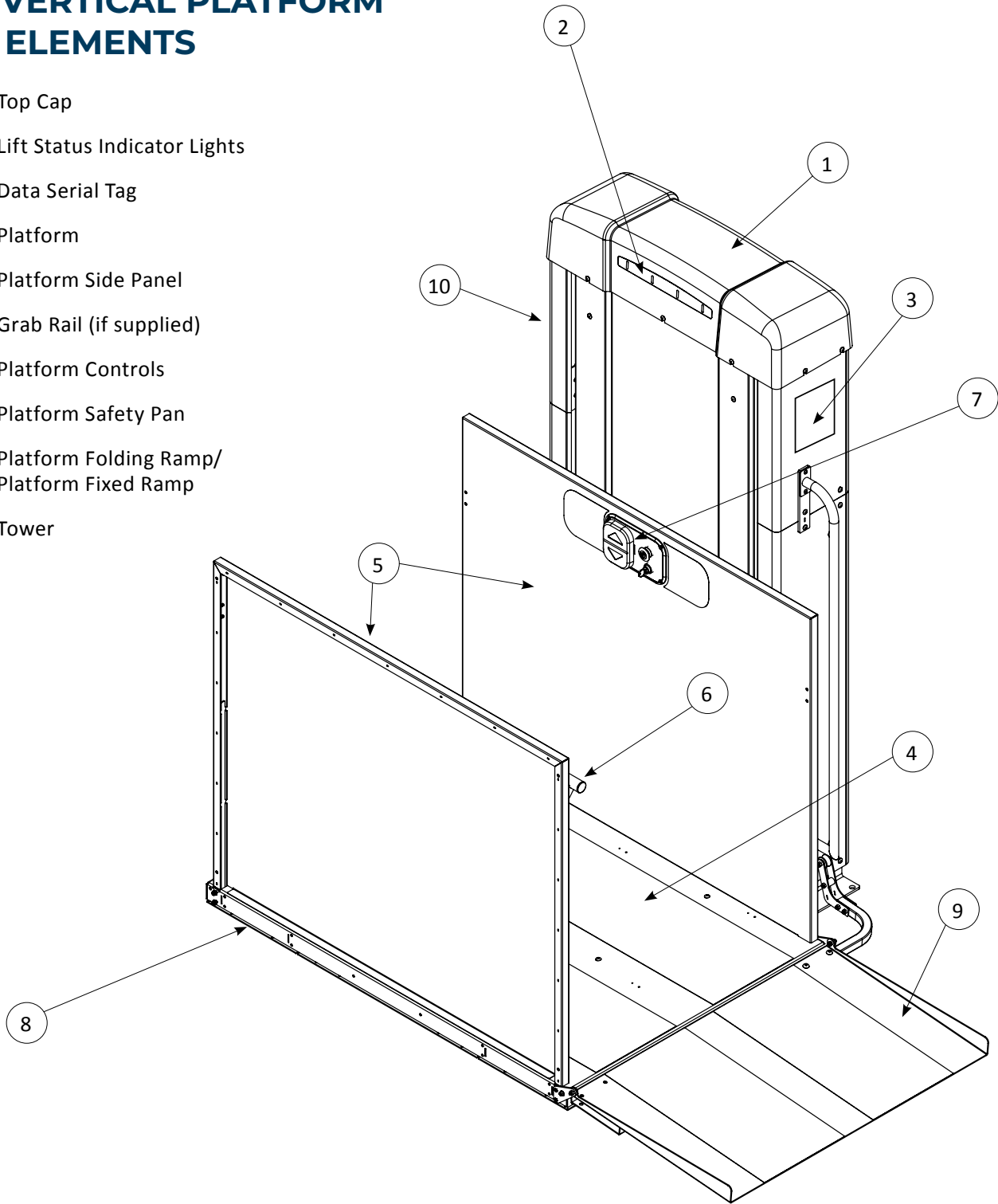

## KEY INTERNAL VERTICAL PLATFORM LIFT ELEMENTS

*NOTE: Do not attempt to troubleshoot. No user serviceable parts inside VPL.*

1. Manual Lowering Tools - see pages 10-11
2. Motor / Gearbox
3. ACME Screw
4. Batteries (if supplied)
5. Battery Charger (if supplied) (not shown)
6. Inverter (if supplied)
7. Control Electronics Assembly
8. Upper / Lower / Final Limit Switches
9. Tower Frame
10. Tower Legs
11. Wire Channel
12. Over-Speed Safety Assembly
13. Motor Contactors
14. Carriage
15. Trailing Cable
16. Cable Tensioning Pulley

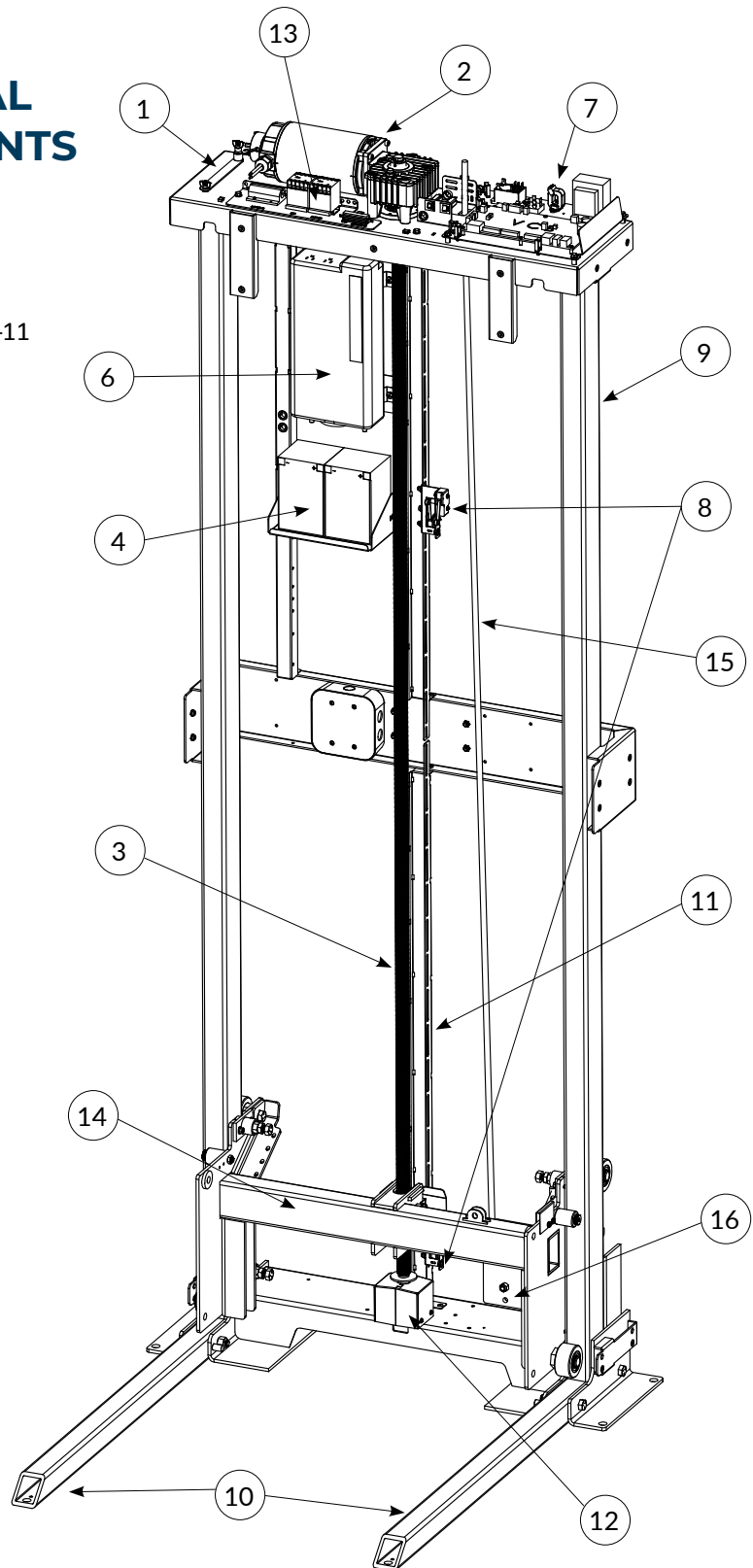

# OPERATION

## SECTION 3

# OPERATION

## HOW THE HARMAR HIGHLANDER II WORKS

The Harmar Highlander II Vertical Platform Lift is AC powered via 115V AC, 15A, single phase, 60Hz. It is available with an optional “Battery Backup” system for instances where the AC power goes out.

The lift is interlocked and will not operate unless all auxiliary gates and appropriate safeties are engaged. The lift will raise or lower once a control input is activated - whether from a call station or from the platform. The platform controls will always override a call station. In either case, a control switch must be continually pressed for the platform to move.

The lifting/lowering of the platform is achieved with a ¾ hp electric motor and gear box driving an ACME screw. That screw system connects to the platform carriage which in turn supports the platform. The platform automatically stops at the desired landing.

The lift has several advanced safety systems based on the status of various sensors and switches located in the tower and at landings. Once a lift is at a landing, the gates/doors will be unlocked and are able to be opened.

## LIFT OPERATION

**⚠ CAUTION**

Prior to every use, please be sure to look around the lift for any signs of damage. Visually inspect anchoring bolts and tower braces and make sure that they are securely in place. Do not use lift if there are any missing or damaged fasteners or other components, they need to be replaced by a qualified technician to ensure continued safe operation.

## CALL/SEND

If the platform is not at your desired landing, you will need to “call” or “send” for it. A Call/Send Control is located at the landing or in the gate frame. The Call/Send Control may have a keylock. Please ensure the key is rotated to the “On” position. Then, to call or send the platform, simply press the Up or Down button, continuously, until the platform comes to a full stop at the desired landing. If unit has 3-Stops (landings) the mid landing Call/Send will “call” the platform to you when both the up and down buttons are pressed simultaneously.

*NOTE: There is a short delay in pressing any call send button before the lift reacts. If there is a platform gate or landing gate, it will not open unless the platform is aligned with the interlock.*

## ENTERING THE PLATFORM

Enter the platform either by opening the gate/door towards you or moving through the opening. Move to the center of the platform while closing the gate/door behind you. If your mobility device has a brake, make sure to engage it. **See Figure 3-1.**

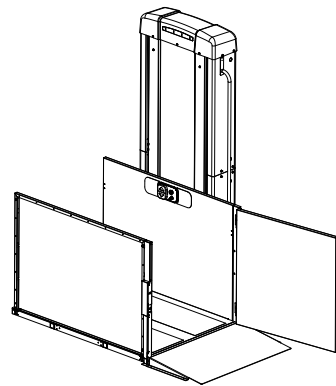

Figure 3-1



## OPERATING THE PLATFORM CONTROLS

Once you are on the platform, locate the Platform Controls on the side panel. If the unit has a key switch, insert the key and turn the key to the “On” position. Check the “Lift Status Indicator Lights” located in the Top Cap and ensure they are Green. 3 flashing Green Lights indicate VPL is running on battery power. *See Figure 3-2.*

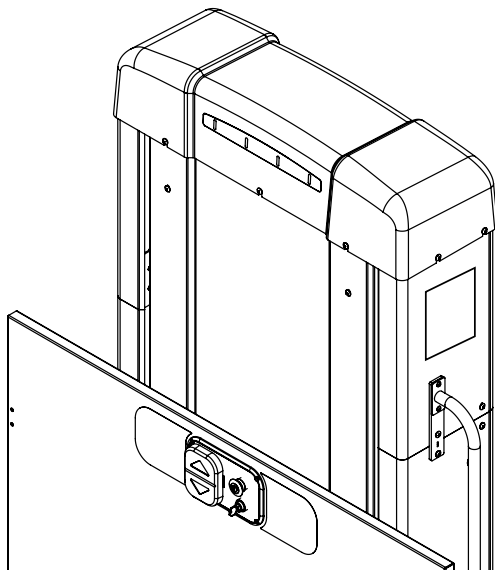

Figure 3-2

### **CAUTION**

If any of the 4 LED lights in the top cap are not green, the unit has reduced function or the unit requires service. Please follow the troubleshooting guide on pages 12-13 in the Owner’s Manual before proceeding to operate the unit.

Once you have confirmed all lights are Green, simply press the desired (up or down) arrow on the blue paddle. The lift will move as long as the paddle control is pressed until you come to a full stop at the desired landing. If your lift has three (3) landings the platform control will have three (3) buttons instead of the

paddle. You may want to hold the hand rail (required on Commercial Lifts) while the lift is in motion.

### **CAUTION**

If you release the blue paddle switch and the unit continues to move, press the Red Emergency Stop Button on the control panel to stop immediately.

### **WARNING**

Do not hold onto the top of the side panel or gate during transport. Keep feet, hands, arms, legs and body well within the confines of the platform during transport.

## EXITING THE PLATFORM

Once you are at the desired landing, the lift will stop and you may release the brakes on your mobility device. When ready to exit, if desired, turn the key switch off and remove the keys.

If your platform has a platform gate or you come to a landing gate or door, those will be able to be opened by pushing outward or will automatically open if you purchased an optional Automatic Door Opener.

*NOTE: If your platform has an automatic folding ramp, it will automatically deploy only at the lower landing.*

### **CAUTION**

Check to make sure the platform is level with the landing. If not, please contact a dealer for assistance.

Once you have exited the platform, ensure the gate or door has closed all the way. Call/Send controls will not work unless doors are closed.

# OPERATION

## RECOMMENDATIONS

**⚠ CAUTION**

Platform lifts should not be used for evacuation during emergencies.

Do not use the lift alone if you are not sure that you can maintain pressure on the control buttons for the duration of travel.

If using the lift alone, it is best practice to have a cell phone with you in case of a malfunction that prevents the platform movement.

If the lift malfunctions while occupied:

- Occupant should follow the directions in the platform cab and never try to evacuate the elevator on their own.
- Contact dealer and/or 911 (dealer's phone number is written on the label next to the cab controls).
- Push in the Red Emergency Stop button on the cab control. If equipped, an alarm will sound.

Once help arrives, they should follow the Emergency Lowering Procedure to evacuate the occupant.

## EMERGENCY LOWERING PROCEDURE

**⚠ WARNING**

Never exit an elevated platform unless it is fully parked at a landing. Do not attempt to manually lower the device while in the platform.

In the event that the lift becomes disabled with passengers on the platform that is not at a landing, it may be necessary/desirable to manually lower them prior to a technician arriving.

In that case, a manual lowering mechanism is located beneath the top cap of the lift. A person other than the lift passenger(s) will be required to make their way to the top of the tower to perform this procedure.

1. Use disconnect to remove all power from lift.
2. Loosen seven (7) screws around the perimeter of the top cap with a Phillips head screwdriver.
3. Lift the top cap partially and disconnect the cable between the top cap at the control board. Set the top cap aside. *See Figure 3-3.*

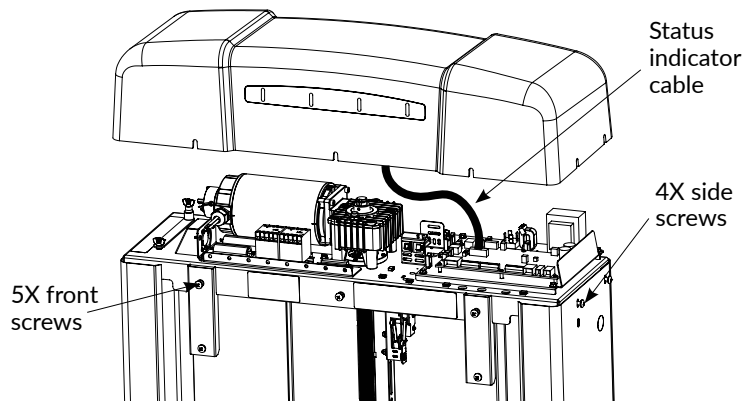

Figure 3-3

4. Remove the two wingnuts holding down the manual lowering tools (1/4" wrench and 1/4" x 3/8" drive socket). *See Figure 3-4.*

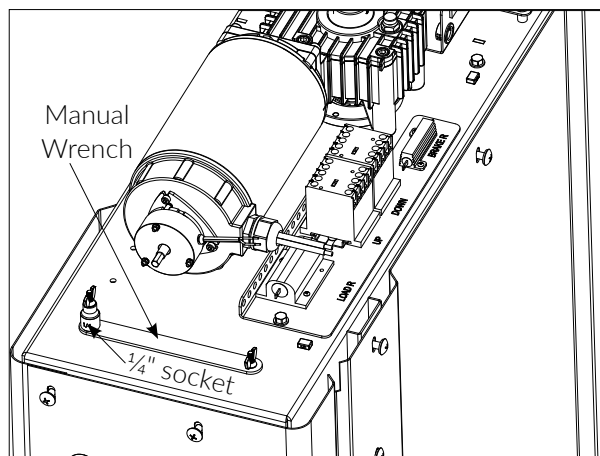

Figure 3-4

- The wrench fits over the 1/4" hex shaft at the end of the drive motor. It is designed to be rotated by hand — clockwise, which will turn the screw and lower the platform.  
**See Figure 3-5.**

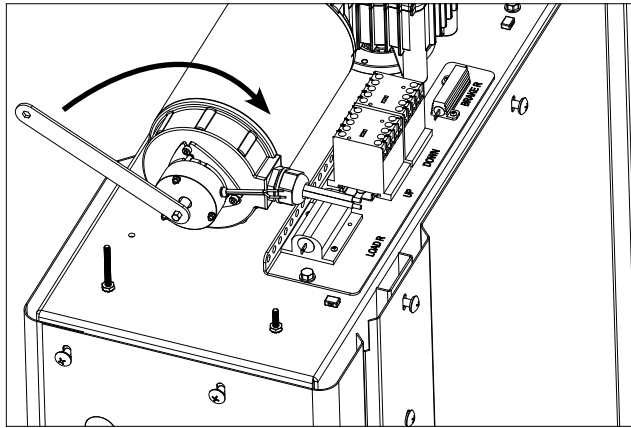

Figure 3-5

- If you have a 3/8" drive ratchet or a cordless drill with a 3/8" socket adapter bit you can use the 1/4" socket for lowering. Power the drill in the forward direction - rotating clockwise to lower the platform. **See Figure 3-6.**

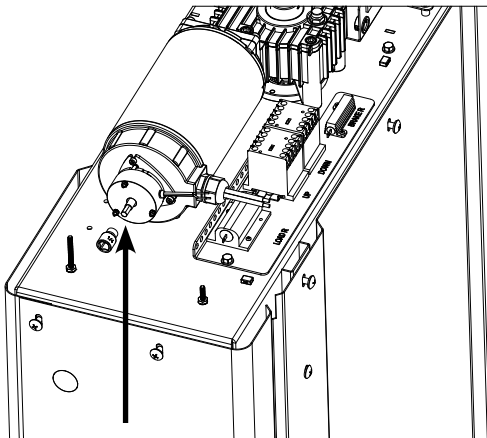

Figure 3-6

*NOTE: The drive motor is equipped with a low holding force brake to prevent the platform from drifting with heavy loads. Lowering the platform with this brake on will require a bit of strength, typically the equivalent of being able to lift 20 lb with one arm.*

- If the lift has power, press and hold the button on the control board labeled BRAKE. This will release the brake and make lowering the platform a little easier.
- Rotate the motor shaft clockwise to lower the platform.

*NOTE: Do not attempt to raise the platform. The required torque to do so is substantially higher.*

- Stop rotation when the platform is level with the lower landing.
- Release the BRAKE button if pressed.
- If the lower gate/door does not open, the crescent key can be used to release it.

**⚠ WARNING**

**Wait for a Harmar dealer to service and inspect the lift prior to using it again.**

SECTION 4  
**TROUBLESHOOTING**

**STATUS CODES**

This lift has several advanced safety systems that monitor various sensors, switches and the performance of the lift. To indicate the status of the VPL there are 4-LEDs located on the Top Cap of the tower. The table below explains the status indicated by the 4-LEDs. LEDs are numbered from left to right, while facing the tower from the platform side. Color listed in brackets indicates LED is flashing.

**See Figure 4-1.**

Refer all other Status Codes to your Harmar dealer.

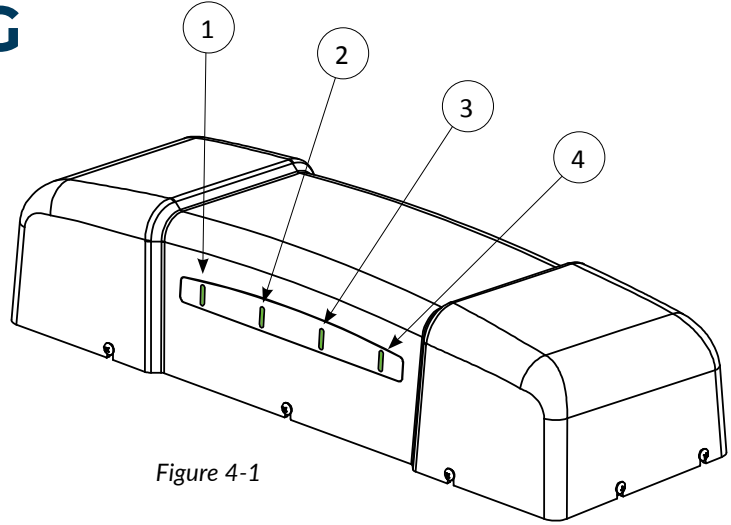



Figure 4-1

*NOTE: [COLOR] means flashing light.*

| Status LED |         |         |         | Status  |
|------------|---------|---------|---------|---|
| #1         | #2      | #3      | #4      |   |
| Green      | Green   | Green   | Green   | <b>All systems normal.</b> Lift is OK to Operate.   |
| [Green]    | [Green] | [Green] | [Green] | <b>Lift is in "Service Mode".</b> DO NOT OPERATE.   |
| [Green]    | [Green] | [Green] |         | <b>Lift is running on backup power.</b> Lift is OK to Operate.  |
| Any Amber  |         |         |         | <b>Lift is OK to Operate.</b> Service is Required.  |
| Amber      | Amber   | Amber   |         | <b>Lift is running on backup power and battery is Low.</b> Lift is OK to Operate for at least one full lift cycle.  |
| [Amber]    | [Amber] | [Amber] |         | <b>Lift is running on backup power and battery is Very Low.</b> Platform will only go down.   |
|            | Amber   | Amber   | Amber   | <b>Lift is on AC power and battery is Low.</b> If lift transfers to backup power it will only operate for at least one full lift cycle. Service or replace batteries. |

| Status LED  |         |         |         | Status  |
|-------------|---------|---------|---------|---|
| #1          | #2      | #3      | #4      |   |
|             | [Amber] | [Amber] | [Amber] | <b>Lift is on AC power and battery is Very Low.</b> If lift transfers to backup power platform will only go down. Service is Required*. |
| Any [Amber] |         |         |         | <b>Minor Fault.</b> Platform function is reduced. Service may be Required.  |
| Red         | Red     | Red     | Red     | <b>Lift will not function.</b> E-Stop is depressed.   |
|             |         | Red     | Red     | <b>Lift will not function.</b> Landing Door is Open.  |
| Red         | Red     |         |         | <b>Lift will not function.</b> Landing Door Lock Failure.   |
| Red         | Red     | Red     |         | <b>Lift will not function.</b> Pit switch is depressed.   |
| Any [Red]   |         |         |         | <b>Lift will not function.</b> Major Fault. Service is required.  |
| All Blank   |         |         |         | <b>Lift will not function.</b> Major Fault, No Power (and no battery) or Low Power Mode. Service is Required.                           |

 **WARNING**

**\*If battery is not replaced promptly after this warning, the battery will further degrade to the point that unit will shut off completely when AC power is lost.**

SECTION 5

**CARE**

To maximize longevity and appearance of your lift, Harmar recommends the following procedures:

- Keep the VPL platform free of debris. Sweeping to clear these areas regularly to prevent debris accumulation is required. Wiping with a damp cloth should be enough for additional surface cleaning. If needed, a soft brush with mild soap and water can be used on the platform and guard ramp surfaces
- You may choose to clean your VPL with soap and water. Turn off VPL and disconnect all power before cleaning. Be sure to rinse all soap from VPL and let the VPL dry before using.
- Keep door hinge hardware lubricated. Once a year use lubricant on the hinges.
- On an outdoor VPL, if the lift will not be used for long periods of time, covering the platform with a tarp and disabling the power is recommended.
- Fully disconnect the lift from all power (AC and Battery Backup) if not using for 2 months or more. Please consult your dealer for proper disconnect procedures.
- Yearly wax (car wax) is an excellent means to protect an outdoor VPL from weathering.

## SECTION 6

# MAINTENANCE & INSPECTION

Except as described elsewhere in this manual, maintenance must be performed only by qualified technicians. Contact your dealer with questions or to schedule any needed inspections, repairs or service.

## REQUIRED INSPECTIONS & MAINTENANCE:

Annual inspections by a qualified technician are highly recommended to help prevent unsafe conditions and operation. Contact your dealer with questions for additional information, to request replacement labels or manuals, or to schedule any needed inspections, repairs or service.

## RESIDENTIAL APPLICATION OWNER/MAINTENANCE

**Before Use:** Do not use lift until these conditions are rectified.

- All doors and gates are locked and secure.
- Check for standing water around the unit.
- Make sure the AC connections are in good condition and that there are no cracks or gaps in conduit.
- Make sure there are no obstructions intruding in the path of the lift.
  - People, tree branches, loose items, etc.
- Check that there is no loose hardware or emerging cracks/deformations in the platform and tower. Make sure that there are no unusual noise or vibrations that develop.

### Periodically:

- Check and ensure that the safety pan under the platform moves freely up and down and is not damaged. This is the built-in safety device designed to detect obstructions under the platform and stop platform downward motion. If there is an easy-to-remove obstruction, please remove it. If for any reason the safety pan does not move as intended, please contact your dealer.
- Check and ensure that all labels are intact and legible. If any safety or warning labels need to be replaced, please contact your dealer.
- Make sure you have a copy of the Owner's Manual. A digital copy of the Owner's Manual is available at [harmar.com](http://harmar.com).
- Check your keylocks and emergency stop button for functionality.
- Check for any rust that may be developing. Rust is expected in outdoor applications (especially in coastal areas), but with proactive maintenance or quick repair, this can be minimized.

## COMMERCIAL APPLICATION END-USER/MAINTENANCE

**IMPORTANT:** Understanding State/Local Inspection Requirements & Timing - Always Required.

**Before Use:** Do not use lift until these conditions are rectified.

- All doors and gates are locked and secure.

# MAINTENANCE

- Check for standing water around the unit.
- Make sure AC connections are in good condition and that there are no cracks or gaps in conduit.
- Make sure there are no obstructions intruding in the path of the lift.
  - People, tree branches, loose items, etc.
- Check that there is no loose hardware or emerging cracks/deformations in the platform and tower.

### Owner/Owner’s Agent:

- Check and ensure that the safety pan under the platform moves freely up and down and is not damaged. This is the built-in safety device designed to detect obstructions under the platform and stop platform downward motion. If there is an easy-to-remove obstruction, please remove it. If for any reason the safety pan does not move as intended, please contact your dealer.
- Check and ensure that all labels are intact and legible. If any safety or warning labels need to be replaced, please contact your dealer.
- Make sure you have a copy of the Owner’s Manual. A digital copy of the Owner’s Manual is available at [harmar.com](http://harmar.com).
- Check your keylocks and emergency stop button for functionality.
- Check for any rust that may be developing. Rust is expected in outdoor applications (especially in coastal areas), but with proactive maintenance or quick repair, this can be minimized.

### Dealer:

- Follow OPERATIONAL CHECK section of the “Install and Service Manual” for the lift if periodic operational checks are required.

## DEALER MAINTENANCE SCHEDULE

### RECOMMENDED EVERY 6-MONTHS

- Check for motor gearbox leaks
- Check wear pads for gaps
- Check all structural connections/hardware
- Inspect the safety brake
- Check the Battery Backup function (if installed)
- Ensure the Power Cut-Off system works as intended
- Check all interlocks, strikes and obstruction sensors
- Check for debris and signs of excessive wear around ACME nuts.
- Clean and grease the lead screw.  
*(Use only Nook PAG-1 ACME Screw Grease)*

### RECOMMENDED ANNUALLY

- Replace batteries (if equipped)

## SERVICE MODE

The “Status Lights” will all flash green in this mode.

## OUT OF SERVICE MODE

If the unit has a major fault that requires service to ensure safe and compliant operation it will enter “Out of Service Mode”. This is indicated on the status indicator as any flashing red light. This cannot be corrected by a power cycle. Call your Harmar dealer immediately.



## MAINTENANCE/SERVICE RECORD

Safety standard ASME A18.1-2020 requires that a log is kept of all service and maintenance performed on this lift in commercial applications. This includes a record of all accidents and a weekly operational check. Refer to “Install and Service Manual” for operational check list. To ensure optimal performance it is recommended that this log is kept for residential applications as well.

| Date | Time | Type of Service (check all that apply) |        |        |          | Notes, Nature of Service/Accident, Parts Replaced,<br>Warranty | Technician |
|------|------|--|--------|--------|----------|--|------------|
|      |      | Check                                  | Repair | Maint. | Accident |  |            |
|      |      |  |        |        |          |  |            |
|      |      |  |        |        |          |  |            |
|      |      |  |        |        |          |  |            |
|      |      |  |        |        |          |  |            |
|      |      |  |        |        |          |  |            |
|      |      |  |        |        |          |  |            |
|      |      |  |        |        |          |  |            |
|      |      |  |        |        |          |  |            |
|      |      |  |        |        |          |  |            |
|      |      |  |        |        |          |  |            |
|      |      |  |        |        |          |  |            |
|      |      |  |        |        |          |  |            |
|      |      |  |        |        |          |  |            |
|      |      |  |        |        |          |  |            |
|      |      |  |        |        |          |  |            |
|      |      |  |        |        |          |  |            |
|      |      |  |        |        |          |  |            |
|      |      |  |        |        |          |  |            |
|      |      |  |        |        |          |  |            |
|      |      |  |        |        |          |  |            |
|      |      |  |        |        |          |  |            |



# MAINTENANCE

| Date | Time | Type of Service (check all that apply) |        |        |          | Notes, Nature of Service/Accident, Parts Replaced, Warranty | Technician |
|------|------|--|--------|--------|----------|---|------------|
|      |      | Check                                  | Repair | Maint. | Accident |   |            |
|      |      |  |        |        |          |   |            |
|      |      |  |        |        |          |   |            |
|      |      |  |        |        |          |   |            |
|      |      |  |        |        |          |   |            |
|      |      |  |        |        |          |   |            |
|      |      |  |        |        |          |   |            |
|      |      |  |        |        |          |   |            |
|      |      |  |        |        |          |   |            |
|      |      |  |        |        |          |   |            |
|      |      |  |        |        |          |   |            |
|      |      |  |        |        |          |   |            |
|      |      |  |        |        |          |   |            |
|      |      |  |        |        |          |   |            |
|      |      |  |        |        |          |   |            |
|      |      |  |        |        |          |   |            |
|      |      |  |        |        |          |   |            |
|      |      |  |        |        |          |   |            |
|      |      |  |        |        |          |   |            |
|      |      |  |        |        |          |   |            |
|      |      |  |        |        |          |   |            |
|      |      |  |        |        |          |   |            |
|      |      |  |        |        |          |   |            |
|      |      |  |        |        |          |   |            |



**MAINTENANCE**

| Date | Time | Type of Service (check all that apply) |        |        |          | Notes, Nature of Service/Accident, Parts Replaced, Warranty | Technician |
|------|------|--|--------|--------|----------|---|------------|
|      |      | Check                                  | Repair | Maint. | Accident |   |            |
|      |      |  |        |        |          |   |            |
|      |      |  |        |        |          |   |            |
|      |      |  |        |        |          |   |            |
|      |      |  |        |        |          |   |            |
|      |      |  |        |        |          |   |            |
|      |      |  |        |        |          |   |            |
|      |      |  |        |        |          |   |            |
|      |      |  |        |        |          |   |            |
|      |      |  |        |        |          |   |            |
|      |      |  |        |        |          |   |            |
|      |      |  |        |        |          |   |            |
|      |      |  |        |        |          |   |            |
|      |      |  |        |        |          |   |            |
|      |      |  |        |        |          |   |            |
|      |      |  |        |        |          |   |            |
|      |      |  |        |        |          |   |            |
|      |      |  |        |        |          |   |            |
|      |      |  |        |        |          |   |            |
|      |      |  |        |        |          |   |            |
|      |      |  |        |        |          |   |            |
|      |      |  |        |        |          |   |            |
|      |      |  |        |        |          |   |            |
|      |      |  |        |        |          |   |            |
|      |      |  |        |        |          |   |            |
|      |      |  |        |        |          |   |            |

# WARRANTY

## SECTION 7

# 3-YEAR LIMITED WARRANTY



**PRODUCTS COVERED: VPL400, VPL600, VPL800, VPL1000, VPL1200, VPL1400 SERIES MODELS**

Your lift came with a separate warranty page on page 21. You must return this page within ten (10) days of installation to register your lift. This warranty policy page must remain in your Owner’s Manual for your records. Do not tear out this page.

Dealer/Installer Name: \_\_\_\_\_

Address: \_\_\_\_\_  
\_\_\_\_\_

Phone: \_\_\_\_\_

E-Mail: \_\_\_\_\_

If you need service or warranty work, your dealer will require the information below to receive factory information or order parts for your VPL.

Date Purchased: \_\_\_\_\_

Serial # of the Lift: \_\_\_\_\_

**THIS EXPRESS WARRANTY IS IN LIEU OF ALL OTHER WARRANTIES OR CONDITIONS, INCLUDING ALL IMPLIED WARRANTIES OR MERCHANTABILITY OR FITNESS FOR A PARTICULAR PURPOSE, AND THERE ARE NO WARRANTIES THAT EXTEND BEYOND THE DESCRIPTION OF THE LIMITED WARRANTY DESCRIBED HEREIN. THIS WARRANTY GIVES YOU SPECIFIC LEGAL RIGHTS AND YOU MAY ALSO HAVE OTHER LEGAL RIGHTS WHICH VARY FROM STATE TO STATE.**

Harmar Mobility warrants, to the original purchaser of a Highlander II Vertical Platform Lift (VPL), that the device has been manufactured by Harmar to be free of defects in material, mechanical and electrical component (parts), excluding labor costs, and paint, for a period of three (3) years from date of installation, provided that the products have been installed, maintained and operated properly. Harmar supplied batteries are limited to one (1) year from date of installation. Paint adhesion and deep rust is limited to one (1) year. Outdoor installation within one (1) mile of coastline expressly excludes rust after 90-days. Cosmetic rust is excluded after 90-days in all applications.

This warranty does not cover maintenance or adjustments. Harmar will not be charged for labor, consequential damage, or repair expenses. Harmar will not, under any circumstances, be liable for the loss of the use of its products or loss of time. This warranty becomes null and void if the product has been lost, damaged by accident, over-stressed, misused and/or neglected, or if the product has been modified in any way. Defective parts must be returned, prepaid, to the address provided by Harmar, for inspection prior to credit, repair, or replacement, at Harmar’s option. Harmar’s sole obligation and the exclusive remedy under this warranty is limited to such credit, repair, or replacement.

**PLEASE FILL OUT ALL FIELDS AND RETURN WITHIN TEN (10) DAYS OF PRODUCT INSTALLATION.**

Fax completed form to 1-866-234-5680 or mail to:  
Harmar, ATTN Warranty Department, 1500 Independence Blvd., Suite 220, Sarasota FL 34234.

**PRODUCT INFORMATION**

Model: \_\_\_\_\_  
Serial Number: \_\_\_\_\_  
Purchase Date: \_\_\_\_\_  
Installation Date: \_\_\_\_\_

**PURCHASER INFORMATION**

Name: \_\_\_\_\_  
Address: \_\_\_\_\_  
\_\_\_\_\_  
Phone: \_\_\_\_\_  
Email: \_\_\_\_\_

**INSTALLER INFORMATION**

Company Name: \_\_\_\_\_  
Contact Name: \_\_\_\_\_  
Address: \_\_\_\_\_  
\_\_\_\_\_  
Phone: \_\_\_\_\_  
Fax: \_\_\_\_\_  
Email: \_\_\_\_\_

**ADDITIONAL INFORMATION**

**How did you hear about Harmar?**

- Harmar Dealer
- Internet
- Magazine  
Which: \_\_\_\_\_
- Friend or Acquaintance
- Saw Harmar product somewhere
- Other: \_\_\_\_\_

**APPLICATION INFORMATION**

Scooter     Power Wheelchair  
 Wheelchair

Year: \_\_\_\_\_  
Manufacturer: \_\_\_\_\_  
Model: \_\_\_\_\_

**Do you have internet access:**     Yes     No

**I purchased my Harmar lift because of:**

- Style/Appearance
- Harmar Representative
- Previous Experience
- Ease of Use
- Recommendation
- Price/Value



Page Intentionally Left Blank

---

---

---

---

---

---

---

---

---

---

---

---

---

---

---

---

---

---

---

---

---

---

---

---

---



1500 Independence Blvd., Suite 220 | Sarasota, FL 34234  
800-833-0478  
[www.harmar.com](http://www.harmar.com)